

INSTALLATION, OPERATING, AND SERVICE INSTRUCTIONS

HEAT-FLO HYDRONIC BUFFER TANKS

MODELS 22-BT-2, 22-BT-4, 30-BT, 40-BT-114, 40-BT-112, 40-BT-2, 60-BT-114, 60-BT-112, 60-BT-2, 80-BT-114, 80-BT-112, 80-BT-2, 115-BT-114, 115-BT-112, 115-BT-2



*Conforms to UL STD 174
Certified to CAN/CSA STD C22.2 No. 110-94*

In order to insure proper service, the following information is provided to assist in enabling the installation, operation, and maintenance of this unit. For your comfort, safety, and convenience, we recommend that this unit be installed and serviced by a plumbing professional. When the installation is completed, keep this manual with the unit. Information and specifications outlined in this manual in effect at the time of printing of this manual. Heat-Flo reserves the right to discontinue, change specifications, or change system design at any time without notice.

Heat-Flo, Inc.
15 Megan Ct., P.O. Box 612 Uxbridge, MA 01569 USA

Bulletin I0-BT-010115

Safety Information

The following terms and symbols are used to bring attention to the presence of various risk levels, or to important information concerning product life.

DANGER

Indicates presence of a hazard, which will cause severe personal injury, death, or substantial property damage if ignored.

WARNING

Indicates the presence of a hazard, which can cause severe personal injury, death, or substantial property damage if ignored.

CAUTION

Indicates the presence of a hazard, which can cause minor personal injury or damage if ignored.

NOTICE

Indicates special instructions on installation, operation, or maintenance, which are important but not related to personal injury hazards.



Heat-flo

Table of Contents

General Information	1, 2
Dimensions and Capacities	3
Buffer Tank Sizing	4
Heat-Flo's Limited Warranty	5, 6

IMPORTANT INFORMATION – READ CAREFULLY

NOTE: The equipment shall be installed in accordance with those installation regulations required in the area where the installation is to be made. These regulations shall be carefully followed in all cases. Authorities having jurisdiction shall be consulted before the installations are made.

All wiring must be in accordance with the National Electrical Code (latest edition) and/or local regulations in the US, and in accordance with the Canadian Electrical Code (latest edition) and/or local regulations in Canada.

▲ WARNING

Improper installation, adjustment, alteration, service or maintenance can cause property damage, personal injury, or loss of life. Read and understand the entire manual before attempting installation, start-up, operation, or service. Installation and service must be performed only by an experienced, skilled installer or service agency.

This tank contains very hot water under high pressure. Do not unscrew any pipe fittings or attempt to disconnect any components of this tank without positively assuring that the water is cool and has no pressure. Always wear protective clothing and equipment when installing, starting up or servicing this tank to prevent scalding injuries. Do not rely on the pressure and temperature gauges to determine the temperature and pressure of the tank. This tank contains components that become very hot when the boiler is operating. Do not touch any components unless they are cool.

Failure to follow all instructions in the proper order can cause personal injury or death. Read all instructions, including all those contained in component manufacturers' manuals before installing, starting up, operating, maintaining, or servicing the tank.

▲ CAUTION

To reduce the risk of excessive pressures and temperatures in this tank, install pressure protective equipment required by local codes but no less than a relief valve certified by a nationally recognized testing laboratory that maintains periodic inspection of production of listed equipment or materials, as meeting the requirements for Relief Valves and Automatic Shutoff Devices for Hot Water Supply Systems, ANSI Z21.22-latest edition. This valve must be marked with a maximum set pressure not to exceed the marked working pressure of the hydronic system. Install the valve and orient it or provide tubing so that any discharge from the valve will exit only within 6 inches above, or at any distance below, the structural floor, and cannot contact any live electrical part. The discharge opening must not be blocked or reduced in size under any circumstances.

▲ DANGER

DO NOT store or use gasoline or other flammable vapors or liquids in the vicinity of this or any other appliance. If you smell gas vapors, DO NOT try to operate any appliance - DO NOT touch any electrical switch or use any phone in the building. Immediately, call the gas supplier from a remotely located phone. Follow the gas supplier's instructions or if the supplier is unavailable, contact the fire department. Do not operate any appliance until the leakage is corrected.

IMPORTANT SAFETY INSTRUCTIONS

READ ALL INSTRUCTIONS BEFORE USING THIS BUFFER TANK.

WARNING

When using electrical appliances, safety precautions should be taken to reduce the risks of fire, electric shock, and injury. These precautions include the following:

- This tank must be grounded if an electrical control is used.
- Install or locate this buffer tank only in accordance with the provided installation instructions.
- Use this tank only for its intended use as described in this manual.
- As with any appliance, close supervision is necessary when used by children.
- This tank should be installed and serviced only by qualified personnel.

SAVE THESE INSTRUCTIONS

Application: Geothermal Heat Pumps/ Chillers/ Low Mass Boilers

The primary application of a buffer tank is to reduce heat pump, chiller, or boiler short cycling. Hydronic buffer tanks are used in systems operating below the design load condition, which is most of the time, or in systems having several low BTU cooling or heating loads calling at different times. This can cause the chiller or boiler to short cycle, resulting in reduced operating efficiency and shorter equipment life.

The hydronic buffer tanks are built with 4 connections. Two connections can be piped to the chiller or boiler, and two connections can be piped to the distribution system. If piped correctly, the tank can serve as both a thermal buffer and a hydraulic separator. The chiller or boiler can be hydraulically decoupled from the distribution system. The tanks are all 316L stainless steel construction with R-12 insulation and an ABS jacket. Buffer tanks are available in 22, 40, 60, 80, and 115 gallon capacities.

A 3/8" ID thermal well is located mid-tank. Thermistors can be inserted 3" into the well, or the well will accept the Honeywell L4006A Controls.

Buffer tanks are available in 22, 40, 60, 80, and 115 gallon capacities.

Specify 1-1/4", 1-1/2", or 2" connections.

The buffer tanks are all stainless steel construction, insulated with a thermoplastic jacket.

⚠ WARNING

DO NOT use in potable water systems.

⚠ WARNING

Use this vessel only in hydronic systems. The installer must comply with all plumbing codes. Do not operate above the temperature or pressure specified on the rating plate. Failure to comply may result in personal injury, property damage, or death.

On the following page, an example of piping a buffer tank is provided, which shows a water source heat pump application. In all applications, note that the tank top fitting should be piped to the distribution supply line and the air purger and vent. This way, the tank will be self venting, and no additional air vent is needed to install or maintain.

The objective in any application is to pipe the buffer tank such that the heating or cooling source is hydraulically decoupled from the distribution system.

Dimensions & Capacities								
	Storage Volume	Dimensions (Inches)				Piping Connections	Max. Tank Working Pressure	Approx. Shipping Wt.
Model	(Gal.)	A (Ht.)	B	C	D (Dia.)	(NPT)	(psi)	(Lbs.)
HF-30-BT	30	34.0	—	—	23.5	1 1/4"	60	77
HF-40-BT-114	40	42.0	31.0	11.0	23.5	1 1/4"	60	87
HF-40-BT-112	40	42.0	31.0	11.0	23.5	1 1/2"	60	87
HF-40-BT-2	40	42.0	31.0	11.0	23.5	2"	60	87
HF-60-BT-114	60	44.0	31.5	11.5	28.0	1 1/4"	60	115
HF-60-BT-112	60	44.0	31.5	11.5	28.0	1 1/2"	60	115
HF-60-BT-2	60	44.0	31.5	11.5	28.0	2"	60	115
HF-80-BT-114	80	54.0	40.5	11.5	28.0	1 1/4"	60	125
HF-80-BT-112	80	54.0	40.5	11.5	28.0	1 1/2"	60	125
HF-80-BT-2	80	54.0	40.5	11.5	28.0	2"	60	125
HF-115-BT-114	115	72.0	61.5	11.5	28.0	1 1/4"	60	160
HF-115-BT-112	115	72.0	61.5	11.5	28.0	1 1/2"	60	160
BT-115-BT-2	115	72.0	61.5	11.5	28.0	2"	60	160

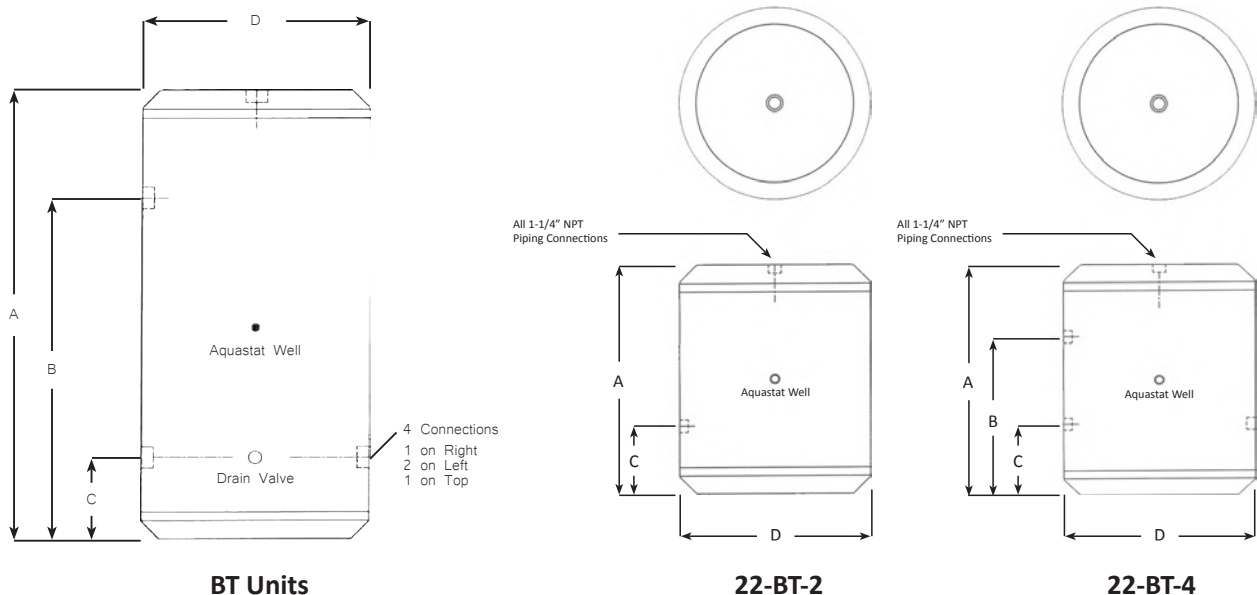

Buffer Tank Sizing: Calculating Capacity

The Heat-Flo buffer tanks are a simple, cost effective way to improve overall system efficiency by reducing unnecessary equipment short cycling. The recommended capacity or volume of a buffer tank is based on four variables:

1. The duration of the heating or cooling source "on time." (Minutes)
 - The desired length of "on time" for each run cycle depends on the type of equipment used. Heat pump and chiller manufacturers typically recommend a minimum of 5 to 10 minutes "on time," and boiler manufacturers may recommend a minimum of 10 minutes "on time." Check with your equipment manufacturer. Generally, the longer the "on time," the higher the overall operating efficiency.
2. The minimum rate of heat input. (BTU/ HR)
 - This is based on the heat pump or chiller output, or the boiler output at the minimum firing rate if the boiler has a variable input system that ramps input down as the demand decreases.
3. The minimum system load (BTU/ HR)
 - This is the demand place on the system with the smallest zone calling for heat.
4. The allowable tank temperature rise. (Deg. F)
 - This varies depending on the type of heating or cooling system used, and on the design of the distribution system. Chillers may require a tight (6 deg. F) differential to assure good dehumidification and prevent freezing; heat pumps may require a 10 deg. F differential to maintain a high COP; and boilers with hydronic heating distribution systems may require a differential anywhere between 10 to 40 deg. F depending on the application.

The following formula determines the tank volume:

$$V = \frac{T \times (Q \text{ heat input} - Q \text{ min. heat load})}{\text{Tank temp. rise} \times 500}$$

V = Buffer Tank Volume (Gallons)

T = Desired Heat Source "on cycle" (Min.)

Q Heat Source = Heat Source Output to Minimum Load

Q Min. Heat Load = Heat Output to Minimum Load

Tank Temp. Rise (deg. F)

Water to Water Heat Pump Example: Town and Country Mechanical wants a minimum heat pump on time of 10 minutes. The heat pump output is 46,500 BTU/ HR. The smallest zone is a 7,000 BTU/ HR bathroom. The allowable temperature differential is 90 to 100 deg. F for the radiant heat zones.

$$V = \frac{10 \times (46,500 - 7,000)}{(100-90) \times 500} = 79.0 \text{ Gallons minimum volume. Choose the HF-80-BT buffer tank.}$$

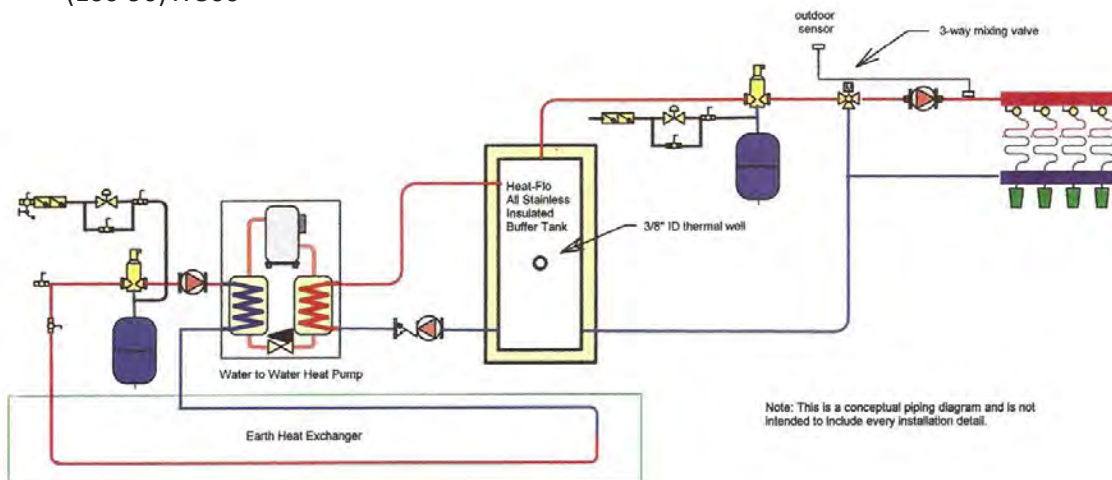

Note: This is a conceptual piping diagram and is not intended to include every installation detail.

Hydronic Buffer Tank applied to Water source heat pump application

Heat-Flo, Inc.
LIMITED WARRANTY
Hydronic Buffer Tank

Your tank is protected by these Heat-Flo, Inc., (HFI), warranties. These warranties are applicable to original consumer purchases only.

WARRANTY COVERAGE FOR RESIDENTIAL USAGE

The warranties listed in this section shall apply to water heaters used in a residential setting by the original consumer purchasers only. A “residential setting” as used herein shall mean usage in a single-family dwelling in which the original consumer purchaser of the water heater resides on a **permanent basis**. “Residential setting shall also mean usage in a multiple family dwelling provided that the water heater services only one (1) dwelling in a multiple family dwelling.

I. LIMITED ONE YEAR WARRANTY

1. Control warranted by original manufacturer for a period of one (1) year.
2. HFI warrants the unit when properly registered with the factory at the time of purchase, as set forth below, to be free from defects in materials and workmanship. HFI will repair, or at its option, replace the unit.

II. LIMITED WARRANTY ON STORAGE TANK/HEAT EXCHANGER ASSEMBLY

HFI further warrants that the storage tank/heat exchanger assembly shall be free from leaks during normal use and service for one of two time periods:

1. **LIMITED FIVE YEAR WARRANTY** – for five years, as long as the original consumer purchaser owns the home (residence) in which the water heater is located.

2. ADDITIONAL LIMITED WARRANTY

HFI further warrants to the original user that for an additional period of ten (10) years from the date of expiration of the first five (5) years of this warranty set forth above, the tank assembly shall be free of leaks during normal use and service. In the event that a leak should develop and occur within this limited warranty period due to a defective material of workmanship, we will furnish a replacement water heater of the nearest comparable model current at the time of replacement. Replacement will be made upon payment by the original user of a percentage of the suggested retail price at the time of replacement as set forth in the following schedule:

Within 6 th through 7 th	- 60%
Within 8 th through 9 th	- 65%
Within 10 th through 11 th	- 70%
Within 12 th through 13 th	- 75%
14 th year and beyond	- 80%

III. EXCLUSIONS AND LIMITATIONS

This warranty extends to the original purchaser only (including first occupants of a new home), is non-transferable and shall apply only if:

1. The unit is correctly installed according to the installation instructions provided with the unit.
2. The unit is operated within the factory specified temperature limits, and at a water pressure not exceeding 150 psi.
3. Components of the water heater which are not defective, but must be replaced as a result of reasonable wear and tear.

4. **Water Quality:** The warranties extended by HFI are conditioned upon potable water with a Ph not to exceed 8.0 and not below 6.0. and / or chloride concentrations not to exceed 100 parts per million (ppm). HFI specifically disclaims liability of any kind resulting from or relating to potable water that does not match these characteristics.
5. Your home contains any type of water softening system, that the system is installed and maintained in accordance with the manufacturer's specifications.
6. Any failure or malfunction does result from improper or negligent operation, accident, abuse (including freezing), misuse, unauthorized alteration or improper repair or maintenance.
7. Any failure or malfunction does not result from failure to keep the unit full of potable water, free to circulate at all times; and the tank free of damaging water sediment or scale deposits.
8. The unit is used within the United States, its territories or possessions, or Canada.
9. The warranty does not cover labor costs, shipping charges, or deliver expenses, nor administrative fees incurred by the purchaser in removing or reinstalling the unit. Heat-Flo will not accept claims for labor costs incurred by the original consumer purchaser in removing or reinstalling the water heater.
10. Malfunctions resulting from, or repairs necessitated by, uses of the water heater for purposes other than that for which it was designed, or resulting from flood, fire, wind, or lightning.

OWNER'S RESPONSIBILITIES

The owner or installer must:

1. Have the storage tank installed with a vacuum relief valve and a temperature and pressure relief valve in accordance with local, state, and federal codes and ordinances bearing the listing marks of the American Society of Mechanical Engineers (A.S.M.E).
2. Operate the storage assembly at a pressure below that shown on the rating plate on the pressure relief valve.
3. Keep the tank free of scale deposits.
4. **Make provisions so if the tank or any component part or connection should leak, the resulting flow of water will not cause damage to the area in which it is installed.**

The warranty hereunder does not apply to defects resulting from:

1. Freezing, excessive pressure, or leaks at water connections.
2. Failure of a component, control or component part other than a component part manufactured solely by HFI.
3. Any cause similar to the above, not resulting solely due to defective material and/or workmanship.
4. **Water Quality:** The warranties extended by HFI are conditioned upon potable water with a Ph not to exceed 8.0 and not below 6.0, and/ or chloride concentrations not to exceed 100 parts per million (ppm). HFI specifically disclaims liability of any kind resulting from or relating to potable water that does not match these characteristics.

LIMITATION OF WARRANTIES AND REMEDIES

THE FOREGOING WARRANTIES ARE EXCLUSIVE AND ARE GIVEN AND ACCEPTED IN LIEU OF ANY AND ALL OTHER WARRANTIES, EXPRESS OR IMPLIED, INCLUDING WITHOUT LIMITATION THE IMPLIED WARRANTIES OF MERCHANTABILITY AND FITNESS FOR PARTICULAR PURPOSE, AND ANY OBLIGATION, LIABILITY, RIGHT, CLAIM, OR REMEDY IN CONTRACT OR TORT, WHETHER OR NOT ARISING FROM HEAT-FLO, INC.'S NEGLIGENCE, ACTUAL OR IMPUTED.

THE REMEDIES OF THE ORIGINAL CONSUMER PURCHASES SHALL BE LIMITED TO THOSE PROVIDED HEREIN TO THE EXCLUSION OF ANY OTHER REMEDIES INCLUDING WITHOUT LIMITATION, INCIDENTAL OR CONSEQUENTIAL DAMAGES INCLUDING, BUT NOT LIMITED TO, PROPERTY DAMAGE, LOST PROFIT, OR DAMAGES ALLEGED TO HAVE BEEN CAUSED BY ANY FAILURE OF HEAT-FLO, INC. TO MEET ANY OBLIGATION UNDER THIS AGREEMENT INCLUDING THE OBLIGATION TO REPAIR AND REPLACE SET FORTH ABOVE.

NO AGREEMENT VARYING OR EXTENDING THE FOREGOING WARRANTIES, REMEDIES, OR THIS LIMITATION WILL BE BINDING UPON HEAT-FLO, INC. UNLESS IN WRITING AND SIGNED BY A DULY AUTHORIZED OFFICER OF HEAT-FLO, INC.

THE WARRANTY STATED HEREIN IS NOT TRANSFERABLE AND SHALL BE FOR THE BENEFIT OF THE ORIGINAL CONSUMER PURCHASER OF A WATER HEATER ONLY.

These warranties give you specific legal rights, and you may also have other rights which may vary from state to state. Some states do not allow the exclusion or limitation of incidental or consequential damages so this limitation or exclusion may not apply to you.

These are the only written warranties applicable to water heaters manufactured and sold by Heat-Flo, Inc. Heat-Flo, Inc. neither assumes nor authorizes anyone to assume for it any other obligation or liability in connection with said water heaters.

SERVICE REQUESTS

FOR SERVICE UNDER THESE WARRANTIES CONTACT HEAT-FLO, INC., AT THIS ADDRESS:

Heat-Flo, Inc., P.O. Box 612, Uxbridge, MA 01569 USA

At the time a claim is filed the original consumer purchaser must present a copy of the original sales receipt, and a deed, utility bill, or equivalent document evidencing both ownership of the water heater and installation in the dwelling or commercial property owned by the original consumer purchaser. With regard to claims made by original consumer purchasers of water heaters used in commercial settings as that term is defined herein, in no event shall notification of a service request be received later than five years from the date of purchase.

he obligations under this warranty apply only to domestic hot water tank installations where the warranty registration card has been completed by the owner of the site of the original installation and received by Heat-Flo in accordance with the terms and conditions herein set out and Heat-Flo has been notified of the alleged defect or deficiency within forty eight (48) hours from the occurrence or discovery of the alleged defect or deficiency.

Heat-Flo, Inc. reserves the right to change specifications or discontinue models without notice.



Heat-flo

RAISING THE STANDARD

Heat-Flo, Inc.

15 Megan Ct., P.O. Box 612, Uxbridge MA, 01569, USA

Phone: (508) 278-2400 | Fax: (508) 278-2466 | e-mail: sales@heat-flo.com

www.heat-flo.com